

The Superior Alternative

MXC™ Tooling System For Thick Turret Punch Presses



mate.com/MXC

Part Number 2010

Worldwide headquarters:

1295 Lund Boulevard, Anoka, Minnesota 55303 USA

Tel 763.421.0230 Fax 763.421.0285 mate.com

MATE®
M
**PRECISION
TOOLING**

TRUSTED | QUALITY | SERVICE | SOLUTIONS

Mate MXC™ Tooling System

Mate's MXC™ Tooling System is a thick turret punching system which increases tool performance and flexibility, offers extended tool life and allows interchangeability with existing systems (see page 11 for details). Some features of the MXC system include:

- **DuraSteel™ punches**
- **100% Compatible with:**
 - HP™
 - HP™ WLS®
 - HP™ ABS
- **Compatible with:**
 - ULTRA TEC®
 - Ultra XT™
- **SLUG FREE® die design**

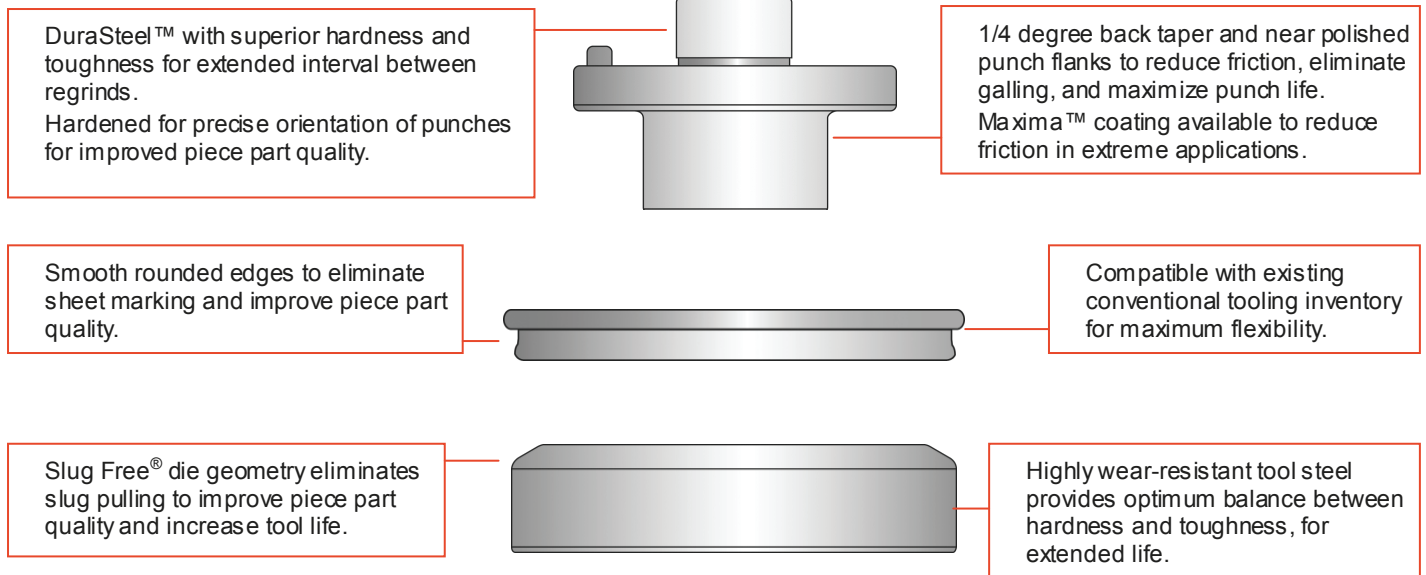

Mate DuraSteel™ High Performance Tool Steel

Mate DuraSteel is a high quality tool steel which has many advantages when compared to alternative tool steels commonly available. These advantages include:

Superior Wear Resistance - Superior resistance to adhesive wear and abrasive wear to maximize the interval between regrinds.

Increased Toughness - The chemical composition and heat treatment processes used make it tougher than conventional tool steels in impact strength tests.

Better Value - Customer trials have shown that tools manufactured with Mate DuraSteel last 100% longer between regrinds than tools manufactured using conventional tool steels. By increasing the interval between regrinds, tooling lasts longer and punches significantly more holes before needing to be replaced.



MXC Thick Turret Tooling System - 1/2" A Station

MXC™ Punch - Standard		Part Number
Round		PXCA0A
Shape		PXCA_A
Maxima™ Coating		
MXC™ Punch - ABS Style*		Part Number
Round		PLCA0A
Shape		PLCA_A
Maxima™ Coating		
MXC™ Stripper		Part Number
Round		SXCA0A
Shape		SXCA_A
Maxima™ Coating		
SLUG FREE® Die		Part Number
Round		D0AA00
Shape		D0AA_0
Maxima™ Coating		
Slug Free Light™ Die		Part Number
Round		add
Shape		add
Die Shim Pack		MCAA
Package 3 each:		
0.016(0.40)		
0.032(0.80)		
0.048(1.20)		

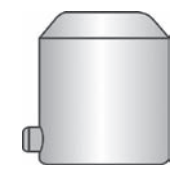
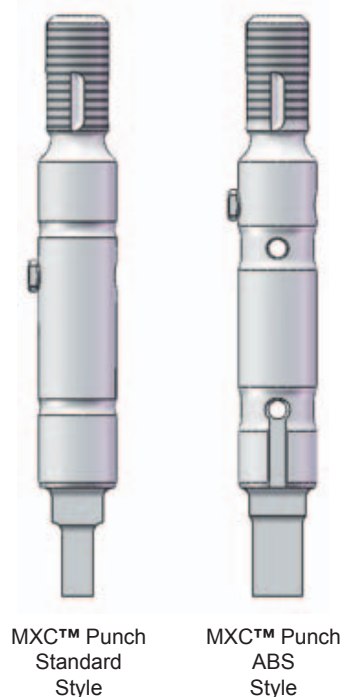

*ABS Style also works in WLS environment

Punch

- DuraSteel™ with superior hardness and toughness for extended interval between regrinds.
- Hardened double-D key for precise orientation of punches for improved piece part quality.
- 1/4 degree back taper and near polished punch flanks to reduce friction, eliminate galling, and maximize punch life.
- Maxima™ coating available to reduce friction in extreme applications. Less friction means less heat build up, less galling and longer tool life.

Stripper

- Smooth rounded edges to eliminate sheet marking and improve piece part quality.
- Compatible with existing conventional tooling inventory for maximum flexibility.

SLUG FREE® Die

- Slug Free die geometry eliminates slug pulling to improve piece part quality and increase tool life.
- Highly wear-resistant tool steel provides optimum balance between hardness and toughness, for extended life.



MXC Thick Turret Tooling System - 1-1/4" B Station

MXC™ Punch - Standard		Part Number
Round		PXCB0A
Shape		PXCB_A
Maxima™ Coating		
Anti-Rotation Pin		MATE00752
Retaining Ring		RR100010
MXC™ Punch - ABS Style		
Round***		PLCB0A
Shape***		PLCB_A
Maxima™ Coating		
Anti-Rotation Pin		MATE00752
Retaining Ring		RR100010
Felt Pad**		FLT00001
MXC™ Stripper		
Round		SXCB0A
Shape		SXCB_A
Retaining Ring*		MATE00754
SLUG FREE® Die		
Round		D0AB00
Shape		D0AB_0
Slug Free Light™ Die		
Round		add
Shape		add
Die Shim Pack Package 3 each: 0.016(0.40) 0.032(0.80) 0.048(1.20)		MSAB

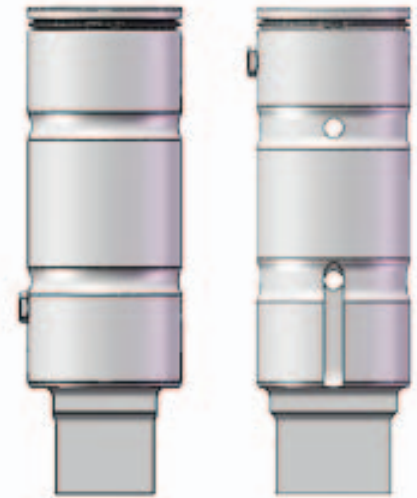

MXC™ Punch
Standard
Style

MXC™ Punch
ABS
Style



* Stripper retaining ring not included with stripper

** Add felt pad (not included with punch) to ABS style punch to work in WLS® environment

*** MXC™ ABS B-station punches are compatible with Wilson Fully Indexable R series 3 station MT for Finn-Power

Standard Shapes:

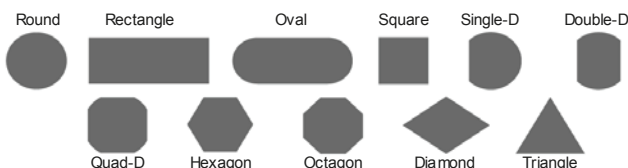

MXC™ Tooling for A and B-stations not available in Belgium, Canada, Denmark, France, Germany, Italy, Japan, Netherlands, Sweden, and United Kingdom. Please contact your Mate representative for more details.

See page 8 for add-ons and accessories

MXC Thick Turret Tooling System - 2" C Station

MXC™ Punch - Standard	Part Number
Round	PXCC0A
Shape	PXCC_A
Maxima™ Coating	
ULTRA TEC® Adapter	A0VCWSPA
MXC™ Stripper	
Round	SXCC0A
Shape	SXCC_A
SLUG FREE® Die	
Round	D0AC00
Shape	D0AC_0
Slug Free Light™ Die	
Round	add
Shape	add
Die Shim Package 3 each: 0.016(0.40) 0.032(0.80) 0.048(1.20)	MSAC

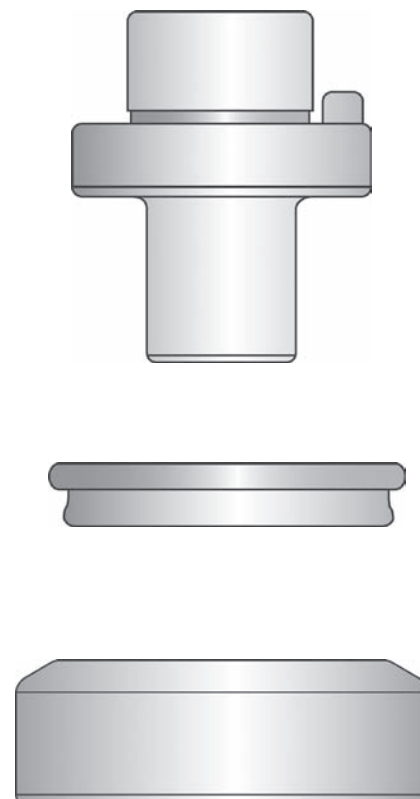

Punch

- DuraSteel™ with superior hardness and toughness for extended interval between regrinds.
- Hardened double-D key for precise orientation of punches for improved piece part quality.
- 1/4 degree back taper and near polished punch flanks to reduce friction, eliminate galling, and maximize punch life.
- Maxima™ coating available to reduce friction in extreme applications. Less friction means less heat build up, less galling and longer tool life.

Stripper

- Smooth rounded edges to eliminate sheet marking and improve piece part quality.
- Compatible with existing conventional tooling inventory for maximum flexibility.

SLUG FREE® Die

- Slug Free die geometry eliminates slug pulling to improve piece part quality and increase tool life.
- Highly wear-resistant tool steel provides optimum balance between hardness and toughness, for extended life.

MXC Thick Turret Tooling System - 3-1/2" D Station

MXC™ Punch - Standard	Part Number
Round	PXCD0A
Shape	PXCD_A
Maxima™ Coating	
ULTRA TEC® Adapter	A0VDWSPA
MXC™ Stripper	
Round	SXCD0A
Shape	SXCD_A
SLUG FREE® Die	
Round	D0AD00
Shape	D0AD_0
Slug Free Light™ Die	
Round	add
Shape	add
Die Shim Package 3 each: 0.016(0.40) 0.032(0.80) 0.048(1.20)	MSAD

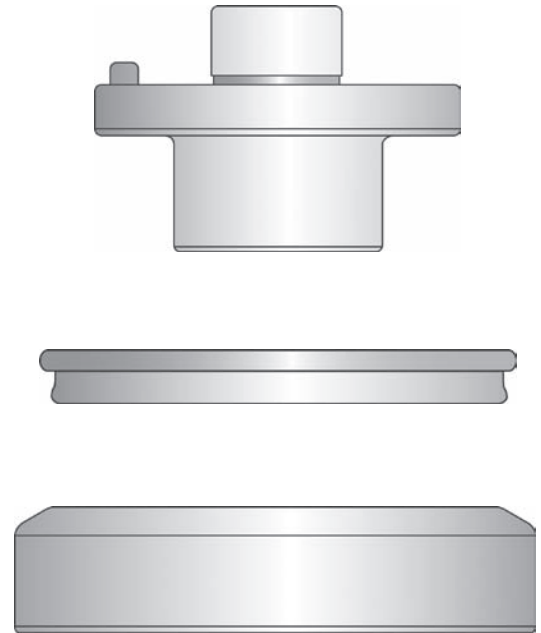

Punch

- DuraSteel™ with superior hardness and toughness for extended interval between regrinds.
- Hardened double-D key for precise orientation of punches for improved piece part quality.
- 1/4 degree back taper and near polished punch flanks to reduce friction, eliminate galling, and maximize punch life.
- Maxima™ coating available to reduce friction in extreme applications. Less friction means less heat build up, less galling and longer tool life.

Stripper

- Smooth rounded edges to eliminate sheet marking and improve piece part quality.
- Compatible with existing conventional tooling inventory for maximum flexibility.

SLUG FREE® Die

- Slug Free die geometry eliminates slug pulling to improve piece part quality and increase tool life.
- Highly wear-resistant tool steel provides optimum balance between hardness and toughness, for extended life.

Standard Shapes:

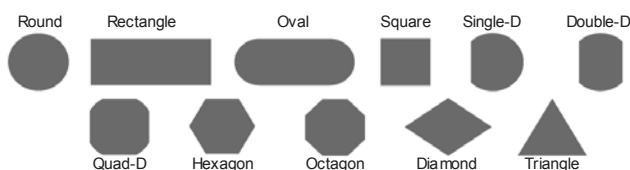

See page 8 for add-ons and accessories

MXC Thick Turret Tooling System - 4-1/2" E Station

MXC™ Punch - Standard	Part Number
Round	PXCE0A
Shape	PXCE_A
Maxima™ Coating	
ULTRA TEC® Adapter	A0VEWSPA
MXC™ Stripper	
Round	SXCE0A
Shape	SXCE_A
SLUG FREE® Die	
Round	D0AE00
Shape	D0AE_0
Slug Free Light™ Die	
Round	add
Shape	add
Die Shim Package 3 each: 0.016(0.40) 0.032(0.80) 0.048(1.20)	MSAE

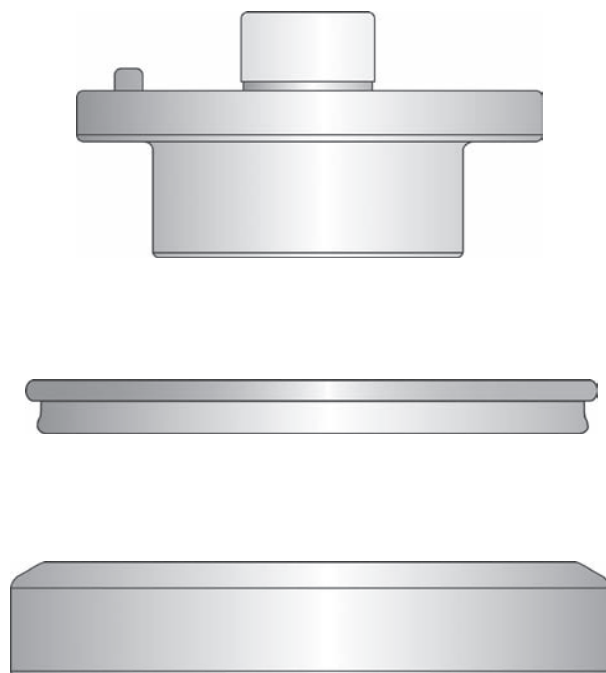

Punch

- DuraSteel™ with superior hardness and toughness for extended interval between regrinds.
- Hardened double-D key for precise orientation of punches for improved piece part quality.
- 1/4 degree back taper and near polished punch flanks to reduce friction, eliminate galling, and maximize punch life.
- Maxima™ coating available to reduce friction in extreme applications. Less friction means less heat build up, less galling and longer tool life.

Stripper

- Smooth rounded edges to eliminate sheet marking and improve piece part quality.
- Compatible with existing conventional tooling inventory for maximum flexibility.

SLUG FREE® Die

- Slug Free die geometry eliminates slug pulling to improve piece part quality and increase tool life.
- Highly wear-resistant tool steel provides optimum balance between hardness and toughness, for extended life.

Standard Shapes:

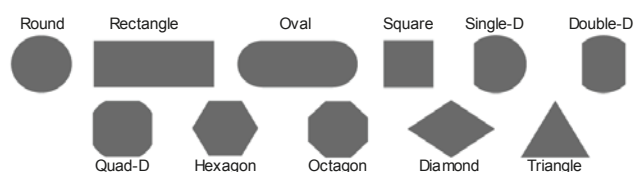

MXC™ Thick Turret Tooling System Add-Ons

Small Diameter Round Tools	
Point diameter 0.031(0.79) - 0.061(1.55) - to punch, stripper and die	add 25%
Point diameter 0.062(1.56) - 0.092(2.35) - to punch, stripper and die	add 10%
Narrow Width Shaped Tools	
Width is less than 0.079(2.00) - to punch, stripper and die	add 25%
Angle Setting	
Non-Standard Angle Setting - to punch, stripper and die	add 25%
Maxima™ Coating	
1/2" A Station	
1-1/4" B Station	
2" C Station	
3-1/2" D Station	
4-1/2" E Station	

MXC™ Thick Turret Tooling System Parts & Accessories



1-1/4" B Station Punch
Retaining Ring
RR100010

Replacement Part



1-1/4" B Station Punch
Anti Rotation Pin
MATE00752

Replacement Part



1-1/4" B Station Punch
Felt Pad
FLT00001

To convert ABS punch
to WLS® style



1-1/4" B Station Stripper
Retaining Ring
MATE00754

Replacement Part



Round Punches Only
Anti-rotation Clip
A0VBWBAC

Replacement Part



2" C Station HP™
Punch Adapter
A0VCWSPA



3-1/2" D Station HP™
Punch Adapter
A0VDWSPA



4-1/2" E Station HP™
Punch Adapter
A0VEWSPA

These Punch Adapters allow an HP™ and/or MXC™ punch to be used
in an Original Style Thick Turret, ULTRA TEC® or ULTRA ABS® holder.

Illustrations not to scale.

Mate Special Shapes

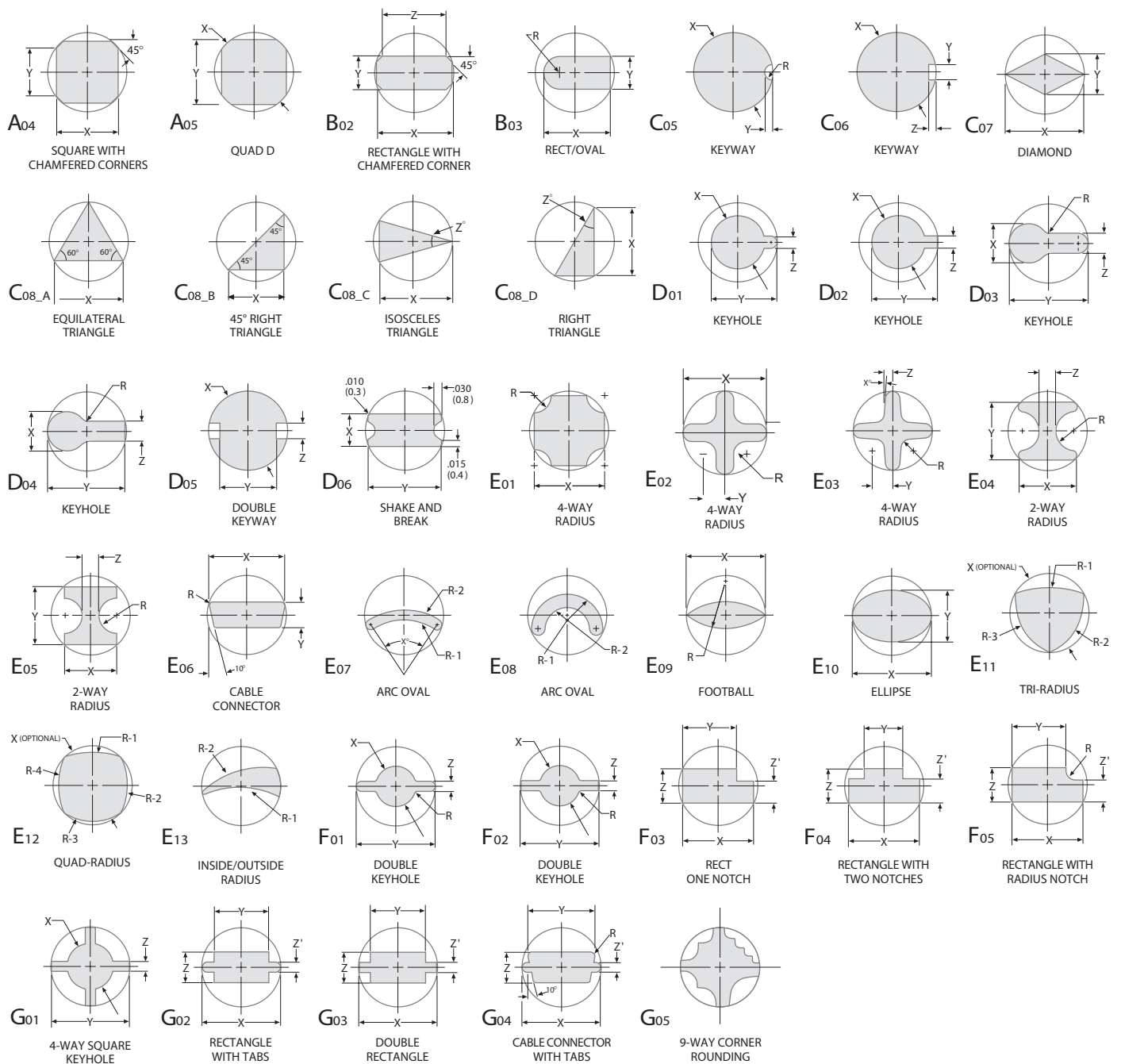

When ordering a special shape, please provide all dimensions noted above for the corresponding shape. Special shape drawings are also available on mate.com.

MXC™ Critical Dimensions Chart

MXC™ PUNCH					
Station	1/2" A	1-1/4" B	2" C	3-1/2" D	4-1/2" E
Part Number	PXCA or PLCA	PXCB or PLCB	PXCC	PXCD	PXCE
Maximum Punch Diagonal	0.500(12.70)	1.250(31.75)	2.000(50.80)	3.500(88.90)	4.500(114.30)
Overall Length	4.640(117.86)	3.957(100.51)	2.360(59.94)	2.360(59.94)	2.360(59.94)
Shank Diameter	0.624(15.85)	1.249(31.72)	1.250(31.75)	1.250(31.75)	1.250(31.75)
Shoulder Diameter	n/a	n/a	2.000(50.80)	3.500(88.90)	4.500(114.30)
Straight Before Radius	0.740(18.80)	0.740(18.80)	1.004(25.50)	1.004(25.50)	1.004(25.50)
MXC™ STRIPPER					
Part Number	SXCA	SXCB	SXCC	SXCD	SXCE
Outside Diameter	0.768(19.51)	1.497(38.02)	2.356(59.84)	4.011(101.88)	4.866(123.60)
Thickness	0.272(6.91)	0.272(6.91)	0.390(9.91)	0.390(9.91)	0.390(9.91)
Stripper Land	0.157(3.99)	0.157(3.99)	0.315(8.00)	0.315(8.00)	0.315(8.00)
SLUG FREE® and SLUG FREE LIGHT™ DIES					
Part Number	D0AA	D0AB	D0AC	D0AD	D0AE
Outside Diameter	1.000(25.40)	1.875(47.63)	3.500(88.90)	4.938(125.43)	6.249(158.72)
Overall Height	1.187(30.15)	1.187(30.15)	1.187(30.15)	1.187(30.15)	1.187(30.15)
Die Penetration	0.118(3.00)	0.118(3.00)	0.118(3.00)	0.118(3.00)	0.118(3.00)

For 1/2" A and
1-1/4" B Station
(B station shown)

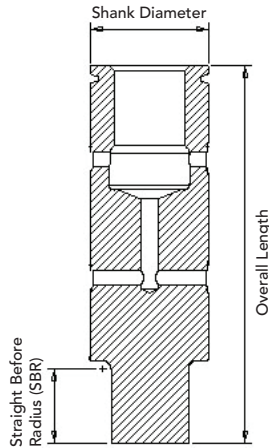

For 2" C, 3-1/2" D and
4-1/2" E Station
(C station shown)

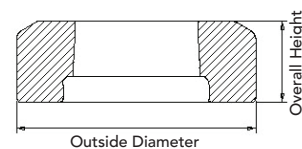
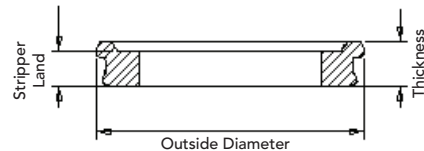
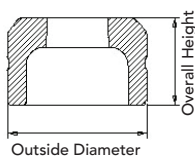
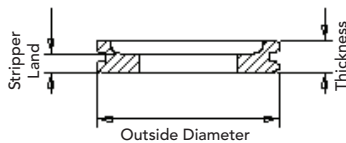
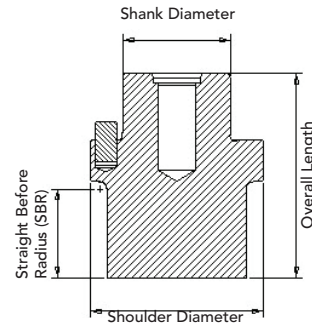

MXC™ Compatibility Chart

Station	Style	Mate Part Number	HP™	HP™ WLS®	HP™ ABS	ULTRA XT™	ULTRA TEC®
1/2" A	MXC™	PXCA	●				
1/2" A	MXC™	SXCA	●	●	●****	●	●
1/2" A	MXC™	D0AA	●	●	●	●	●
1/2" A	MXC™ ABS Style	PLCA		●	●		
1/2" A	MXC™	SXCA	●	●	●****	●	●
1/2" A	MXC™	D0AA	●	●	●	●	●
1-1/4" B	MXC™	PXCB	●			●*	●*
1-1/4" B	MXC™	SXCB	●	●	●****	●	●
1-1/4" B	MXC™	D0AB	●	●	●	●	●
1-1/4" B	MXC™ ABS Style	PLCB		●	●	● Round only	●*
1-1/4" B	MXC™	SXCB	●	●	●****	●	●
1-1/4" B	MXC™	D0AB	●	●	●	●	●
2" C	MXC™	PXCC	●	●	●	●**	●**
2" C	MXC™	SXCC	●	●	●****		
2" C	MXC™	D0AC	●	●	●	●	●
3-1/2" D	MXC™	PXCD	●	●	●	●**	●**
3-1/2" D	MXC™	SXCD	●	●	●****		
3-1/2" D	MXC™	D0AD	●	●	●	●	●
4-1/2" E	MXC™	PXCE	●	●	●	●**	●**
4-1/2" E	MXC™	SXCE	●	●	●****		
4-1/2" E	MXC™	D0AE	●	●	●	●	●

* To use round or shaped MXC™ B-Station punches in Mate ULTRA TEC® or Ultra XT™ guides, first remove both the retaining ring (RRI00019) and anti-rotation pin (MATE00752). Shaped punches are then ready to use. For round punches, install the anti-rotation clip (A0VBWBAC) in place of the retaining ring. Please note that shaped MXC™ ABS Style B-Station punches cannot be made to work in Ultra XT™ guides.

** Use an HP™ Adapter to allow an HP™ punch, or MXC™ C, D, and E punches to be used in Mate ULTRA TEC® or Mate ULTRA ABS® guide assemblies. For more information about the Mate ULTRA® precision tooling system, please visit www.mate.com/ultra

*** HP™ was formerly known as Series 90®.

**** Mate has verified in testing that the standard strippers with normal clearance delivers sufficient lubrication to the punch point.





MATE®
M
**PRECISION
TOOLING**
mate.com



The Mate logo is a registered trademark of Mate Precision Tooling Inc. in the USA, Canada, China, Germany, India, Sweden, and U.K. SLUG FREE, ULTRA ABS, and ULTRA TEC are registered trademarks of Mate Precision Tooling Inc. Maxima, MXC, Slug Free Light, and Ultra XT are trademarks of Mate Precision Tooling Inc. All trademark names mentioned in this document are the property of their respective owners.

Mate Tooling Lasts Longer

1295 Lund Boulevard, Anoka, Minnesota 55303 USA
Call 763.421.0230 • Fax 763.421.0285 • mate.com